



Fleetneck | Pintle Hitch

FMAX207 | FMAX208 | FMAX307 | FMAX210 | FMAX210SS | FMAX212 | FMAX212SS
FMAX310 | FMAX312 | FMAX216 | PX210 | PX212 | PX310 | PX312 | PX216



Do Work. Love Strong.

Our Story.



34 years ago a young East Texas couple embarked on a journey that at the time was merely a means to put food on the table for their growing family. Unbeknownst to them, their nature would have an endless impact on the business they would create.

LOVE STRONG. From 1981-1984 Kim Crabb worked for a local trailer manufacturer that ultimately went out of business leaving customers without product and workers without a job. With Kim's heart and desire to positively impact people, she embraced Mike's idea to start their own trailer business. Needless to say, they were all in and Diamond C was born.

DO WORK. Mike's construction and auto/body background, combined with his grit, knack for quality and resolve to improve customer experience through innovation, quickly set the stage for Diamond C to become a bold brand about much more than just building trailers.

Today, Diamond C is still a family owned and operated company that continues striving to produce innovative, feature-rich trailers. Thus allowing the company to live out its purpose of promoting the well being and success of its team members, customers and communities.

[#BeTheDifference](#) [#DoWorkLoveStrong](#)

Gooseneck Trailers

We are forging a new era in flatbed goosenecks with the Fleetneck Engineered Beam series. We design, engineer, and optimize our own U.S. Patent Protected I-Beams to fit each Fleetneck model. Fleetnecks are stronger yet lighter, featuring the best strength-to-weight ratios of any steel frame gooseneck on the road.



Model: FMAX212



Model: FMAX310

LIGHTER. STRONGER. #DOWORK



Model: FMAX207

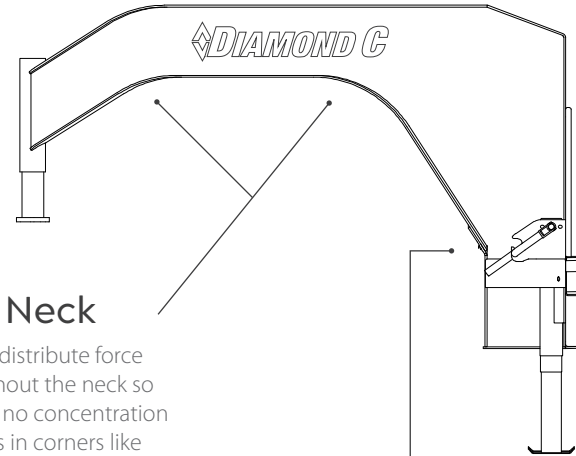

The Neck

Curves distribute force throughout the neck so there is no concentration of stress in corners like traditional goosenecks.

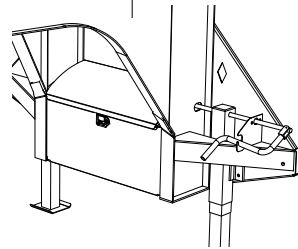

The Box

It's big and roomy. The lid is curved for added rigidity and gas spring assisted for easy operation.

The Deck

It's low profile for easy access. Tire-covers are HD 3/16" diamond plate. Boards are capped at each end of the deck for added durability.

The Camber

The deck and frame have a slight camber when not loaded. When loaded, it flexes as necessary to level but never sags like traditional goosenecks.

The Lace-rail

Channel-Iron for durability and versatility with no notches or cut-outs for maximum strength. Includes stake-pockets and pipe-spools.

The Steps

The retractable front deck steps solve the common issue of traditional front deck steps being bent in low clearance situations. The mid-deck side turn signal step makes for easy access when equipment is loaded.

The I-Beams

We set out to design, engineer, and build our own I-beams. Now we have an almost infinite control over the shape of the beams. We're able to optimize the performance of the steel by putting it to work where we need it most. No dead weight. No added reinforcements needed. Our beams are the tallest and strongest in gooseneck trailers, with the best strength-to-weight ratios on the road.



Model: FMAX212

FRONT
RETRACTABLE STEP



AIR RIDE SUSPENSION

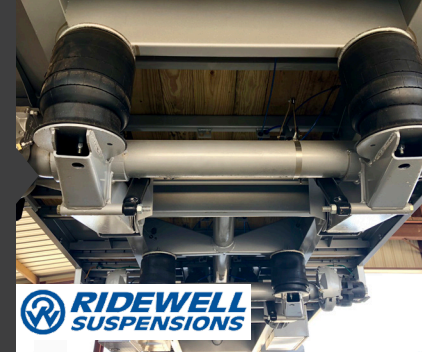

BOLT-ON/WELD-ON
DECK ON THE DECK



SWAY CONTROL



BOLT-ON LED FLOOD
LIGHTS, 2700 LUMEN



102" UNDERSLUNG
DUNNAGE RACK





FMAX207

Single Wheel Tandem Axle Gooseneck

Standard Features

- **AVAILABLE SIZES** - 20' x 102", 22' x 102", 25' x 102", 28' x 102", 30' x 102", 32' x 102", 35' x 102"
- **GVWR** - 15,500 lb
- **LOADING STYLE** - 12' Hydraulic Dovetail, Max Ramps, or Straight Deck
- **AXLES** - 2 - 7,000 lb E-Z Lube , "Nev-R-Adjust" Electric Brakes
- **COUPLER** - 25,000 lb Bulldog BX1
- **CROSS-MEMBERS** - 3" Channel on 16" Centers w/Formed Gussets
- **FRAME** - 14" Engineered Beam (Low Profile)
- **JACK** - 7,000 lb Drop-Leg
- **NECK** - 12" Engineered Neck
- **STAKE POCKETS** - 2" x 3/8" Rub Rail w/ Stake Pockets & Pipe Spools
- **STORAGE** - Diamond Plate Neck Box w/ Gas Shock Assisted Lid
- **SWAY CONTROL** - Standard on 30' - 35' models
- **TIRES** - ST235/80R16 Radial

Popular Upgrades

- Electric-Over-Hydraulic Disk Brakes
- ST235/80R16 14 Ply Radial Tires
- Sway Control Pipe (for 20' - 28' models)



FMAX208

Single Wheel Tandem Axle Gooseneck

Standard Features

- **AVAILABLE SIZES** - 20' x 102", 22' x 102", 25' x 102", 28' x 102", 30' x 102", 32' x 102", 35' x 102", 38' x 102", 40' x 102"
- **GVWR** - 18,000 lb
- **LOADING STYLE** - 12' Hydraulic Dovetail, Max Ramps, or Straight Deck
- **AXLES** - 2 - 8,000 lb Oil Bath Electric Brakes
- **COUPLER** - 25,000 lb Bulldog BX1
- **CROSS-MEMBERS** - 3" Channel on 16" Centers w/Formed Gussets
- **FRAME** - 16" Engineered Beam (Low Profile)
- **JACK** - 2 - 12,000 lb Drop-Leg Jacks
- **NECK** - 12" Engineered Neck
- **STAKE POCKETS** - 2" x 3/8" Rub Rail w/ Stake Pockets & Pipe Spools
- **STORAGE** - Diamond Plate Neck Box w/ Gas Shock Assisted Lid
- **SWAY CONTROL** - Standard on 30' - 40' models
- **TIRES** - ST215/75R17.5 Radial

Popular Upgrades

- Bolt-On LED Flood Lights
- Blackwood Floor
- 2 - 12,000 lb Hydraulic Jacks



FMAX307

Single Wheel Triple Axle Gooseneck

Standard Features

- **AVAILABLE SIZES** - 25' x 102", 28' x 102", 30' x 102", 32' x 102", 35' x 102", 38' x 102", 40' x 102"
- **GVWR** - 24,000 lb
- **LOADING STYLE** - 12' Hydraulic Dovetail, Max Ramps, or Straight Deck
- **AXLES** - 3 - 7,000 lb E-Z Lube , "Nev-R-Adjust" Electric Brakes
- **COUPLER** - 25,000 lb Bulldog BX1
- **CROSS-MEMBERS** - 3" Channel on 16" Centers w/Formed Gussets
- **FRAME** - 16" Engineered Beam (Low Profile)
- **JACK** - 2 - 12,000 lb Drop-Leg Jacks
- **NECK** - 12" Engineered Neck
- **STAKE POCKETS** - 2" x 3/8" Rub Rail w/ Stake Pockets & Pipe Spools
- **STORAGE** - Diamond Plate Neck Box w/ Gas Shock Assisted Lid
- **SWAY CONTROL** - Standard on 30' - 40' models
- **TIRES** - ST235/80R16 Radial

Popular Upgrades

- Blackwood Floor
- 14" x 14" x 36" Under-Slung Box
- ST215/75R17.5 Radial Tires



FMAX210

Tandem Dual Wheel Gooseneck

Standard Features

- **AVAILABLE SIZES** - 20' x 102", 22' x 102", 25' x 102", 28' x 102", 30' x 102", 32' x 102", 35' x 102", 38' x 102", 40' x 102"
- **GVWR** - 25,000 lb
- **LOADING STYLE** - 12' Hydraulic Dovetail, Max Ramps, or Straight Deck
- **AXLES** - 2 - 10,000 lb General Duty Electric Brake, Oil Bath
- **COUPLER** - 25,000 lb Bulldog BX1
- **CROSS-MEMBERS** - 3" Channel on 16" Centers w/Formed Gussets
- **FRAME** - 16" Engineered Beam (Low Profile)
- **JACK** - 2 - 12,000 lb Drop-Leg Jacks
- **NECK** - 12" Engineered Neck
- **STAKE POCKETS** - 2" x 3/8" Rub Rail w/ Stake Pockets & Pipe Spools
- **STORAGE** - Diamond Plate Neck Box w/ Gas Shock Assisted Lid
- **SWAY CONTROL** - Standard on 30' - 40' models
- **TIRES** - ST235/80R16 Radial

Popular Upgrades

- Electric-Over-Hydraulic Drum or Disc Brakes
- 7' x 8" Weld-On/Bolt-On Deck on the Neck
- Black Wheels



FMAX210SS

Tandem Super Single Gooseneck

Standard Features

- **AVAILABLE SIZES** - 20' x 102", 22' x 102", 25' x 102", 28' x 102", 30' x 102", 32' x 102", 35' x 102", 38' x 102", 40' x 102"
- **GVWR** - 25,000 lb
- **LOADING STYLE** - 12' Hydraulic Dovetail, Max Ramps, or Straight Deck
- **AXLES** - 2 - 10,000 lb General Duty Electric Brake, Oil Bath
- **COUPLER** - 25,000 lb Bulldog BX1
- **CROSS-MEMBERS** - 3" Channel on 16" Centers w/Formed Gussets
- **FRAME** - 16" Engineered Beam (Low Profile)
- **JACK** - 2 - 12,000 lb Drop-Leg Jacks
- **NECK** - 12" Engineered Neck
- **STAKE POCKETS** - 2" x 3/8" Rub Rail w/ Stake Pockets & Pipe Spools
- **STORAGE** - Diamond Plate Neck Box w/ Gas Shock Assisted Lid
- **SWAY CONTROL** - Standard on 30' - 40' models
- **TIRES** - ST235/75R17.5 18 Ply Radial, Super Single

Popular Upgrades

- 14" x 14" x 36" Under-Slung Box
- 2 - 12,000 lb Hydraulic Jacks
- Blackwood Floor



FMAX212

Tandem Dual Wheel Gooseneck

Standard Features

- **AVAILABLE SIZES** - 20' x 102", 22' x 102", 25' x 102", 28' x 102", 30' x 102", 32' x 102", 35' x 102", 38' x 102", 40' x 102", 44' x 102"
- **GVWR** - 25,900 lb
- **LOADING STYLE** - 12' Hydraulic Dovetail, Max Ramps, or Straight Deck
- **AXLES** - 2 - 12,000 lb General Duty Electric Brake, Oil Bath
- **COUPLER** - 30,000 lb Bulldog BX1
- **CROSS-MEMBERS** - 3" Channel on 16" Centers w/Formed Gussets
- **FRAME** - 16" Engineered Beam 20'- 40' (Low Profile) 18" Engineered Beam - 44' (Low Profile)
- **JACK** - 2 - 12,000 lb Drop-Leg Jacks
- **NECK** - 12" Engineered Neck
- **STAKE POCKETS** - 2" x 3/8" Rub Rail w/ Stake Pockets & Pipe Spools
- **STORAGE** - Diamond Plate Neck Box w/ Gas Shock Assisted Lid
- **SWAY CONTROL** - Standard on 30' - 44' models
- **TIRES** - ST235/80R16 Radial, Dually

Popular Upgrades

- Electric-Over-Hydraulic Disc Brakes
- Air Ride Suspension
- Full Length Slide Track

Fleetneck Trailer Models, cont.



FMAX212SS

Tandem Super Single Gooseneck

Standard Features

- **AVAILABLE SIZES** - 20' x 102", 22' x 102", 25' x 102", 28' x 102", 30' x 102", 32' x 102", 35' x 102", 38' x 102", 40' x 102", 44' x 102"
- **GVWR** - 25,900 lb
- **LOADING STYLE** - 12' Hydraulic Dovetail, Max Ramps, or Straight Deck
- **AXLES** - 2 - 12,000 lb General Duty Electric Brake, Oil Bath
- **COUPLER** - 30,000 lb Bulldog BX1
- **CROSS-MEMBERS** - 3" Channel on 16" Centers w/Formed Gussets
- **FRAME** - 16" Engineered Beam 20'- 40' (Low Profile)
18" Engineered Beam - 44' (Low Profile)
- **JACK** - 2 - 12,000 lb Drop-Leg Jacks
- **NECK** - 12" Engineered Neck
- **STAKE POCKETS** - 2" x 3/8" Rub Rail w/ Stake Pockets & Pipe Spools
- **STORAGE** - Diamond Plate Neck Box w/ Gas Shock Assisted Lid
- **SWAY CONTROL** - Standard on 30' - 44' models
- **TIRES** - ST235/75R17.5 18 Ply Radial, Super Single

Popular Upgrades

- 3" Channel Cross-Members on 12" Centers w/Formed Gussets
- Black Wheels
- 14" x 14" x 36" Under-Slung Box



FMAX310

Triple Dual Wheel Gooseneck

Standard Features

- **AVAILABLE SIZES** - 25' x 102", 28' x 102", 30' x 102", 32' x 102", 35' x 102", 38' x 102", 40' x 102", 44' x 102"
- **GVWR** - 30,000 lb
- **LOADING STYLE** - 12' Hydraulic Dovetail, Max Ramps, or Straight Deck
- **AXLES** - 3 - 10,000 lb General Duty Electric Brake, Oil Bath
- **COUPLER** - 30,000 lb Bulldog BX1
- **CROSS-MEMBERS** - 3" Channel on 16" Centers w/Formed Gussets
- **FRAME** - 16" Engineered Beam 20'- 32' (Low Profile)
18" Engineered Beam 35' - 44' (Low Profile)
- **JACK** - 2 - 12,000 lb Drop-Leg Jacks
- **NECK** - 12" Engineered Neck
- **STAKE POCKETS** - 2" x 3/8" Rub Rail w/ Stake Pockets & Pipe Spools
- **STORAGE** - Diamond Plate Neck Box w/ Gas Shock Assisted Lid
- **SWAY CONTROL** - Standard on 30' - 44' models
- **TIRES** - ST235/80R16 Radial, Dually

Popular Upgrades

- Blackwood Floor
- Deck on the Neck
- ST235/80R16 14 Ply Radial Tires



FMAX312

Triple Dual Wheel Gooseneck

Standard Features

- **AVAILABLE SIZES** - 25' x 102", 28' x 102", 30' x 102", 32' x 102", 35' x 102", 38' x 102", 40' x 102", 44' x 102"
- **GVWR** - 30,000 - 40,000 lb
- **LOADING STYLE** - 12' Hydraulic Dovetail, Max Ramps, or Straight Deck
- **AXLES** - 3 - 12,000 lb General Duty Electric Brake, Oil Bath
- **COUPLER** - 30,000 lb Bulldog BX1
- **CROSS-MEMBERS** - 3" Channel on 16" Centers w/Formed Gussets
- **FRAME** - 16" Engineered Beam 20'- 32' (Low Profile)
18" Engineered Beam 35' - 44' (Low Profile)
- **JACK** - 2 - 12,000 lb Drop-Leg Jacks
- **NECK** - 12" Engineered Neck
- **STAKE POCKETS** - 2" x 3/8" Rub Rail w/ Stake Pockets & Pipe Spools
- **STORAGE** - Diamond Plate Neck Box w/ Gas Shock Assisted Lid
- **SWAY CONTROL** - Standard on 30' - 44' models
- **TIRES** - ST235/80R16 Radial, Dually

Popular Upgrades

- 14" x 14" x 36" Under-Slung Box
- HDSS Suspension
- ST215/75R17.5 Radial Dually Tires



FMAX216

Tandem Dual Wheel Gooseneck

Standard Features

- **AVAILABLE SIZES** - 20' x 102", 22' x 102", 25' x 102", 28' x 102", 30' x 102", 32' x 102", 35' x 102", 38' x 102", 40' x 102", 44' x 102"
- **GVWR** - 30,000 - 40,000 lb
- **LOADING STYLE** - 12' Hydraulic Dovetail, Max Ramps, or Straight Deck
- **AXLES** - 2 - 16,000 lb General Duty Electric Brake, Oil Bath
- **COUPLER** - 30,000 lb Bulldog BX1
- **CROSS-MEMBERS** - 3" Channel on 16" Centers w/Formed Gussets
- **FRAME** - 16" Engineered Beam 20'- 32' (Low Profile)
18" Engineered Beam 35' - 44' (Low Profile)
- **JACK** - 2 - 12,000 lb Drop-Leg Jacks
- **NECK** - 12" Engineered Neck
- **STAKE POCKETS** - 2" x 3/8" Rub Rail w/ Stake Pockets & Pipe Spools
- **STORAGE** - Diamond Plate Neck Box w/ Gas Shock Assisted Lid
- **SWAY CONTROL** - Standard on 30' - 44' models
- **TIRES** - ST215/75R17.5 Radial, Dually

Popular Upgrades

- 40,000 lb GVWR Package
- 2 - 25,000 lb Two Speed Drop-Leg Jacks
- Air Ride Suspension

Check out www.diamondc.com

With our Interactive "Build Your Own Trailer" Feature

SINGLE WHEEL TANDEM AXLE GOOSENECK

Model: FMAX207

[BUILD YOUR OWN TRAILER](#)

Sporting a class exclusive patented 14" Engineered Beam frame, the FMAX207 is in a league of its own.

Fleetneck Style

Choose Tail Style:	<input checked="" type="radio"/> Max Ramps	<input type="radio"/> 12" Hydraulic Dovetail	<input type="radio"/> Straight Deck
--------------------	--	--	-------------------------------------

Length/Width

Max Ramps 25' x 102"

GVWR

35,000 lb

Dove

<input checked="" type="radio"/> 60" Dovetail with 2" x 2" x 60" Angle Cleats (Max Ramps)	<input type="radio"/> Wood Filled Dove/Ramp (Max Ramps)
---	---

Pintle Hitch Trailers

This PX lineup of heavy duty pintle ring equipment trailers feature the same industry shaking Engineered Beam technology found in our legendary Fleetneck series of gooseneck trailers. A PX is ready for the toughest of jobs you can throw at it, the question is - Are you?



Model: PX210



Model: PX312



Model: PX310



PX210

Tandem Dual Wheel Pintle Hitch

Standard Features

- **AVAILABLE SIZES** - 20' x 102", 22' x 102", 25' x 102", 28' x 102", 30' x 102", 32' x 102", 35' x 102", 38' x 102", 40' x 102"
- **GVWR** - 25,000 lb
- **LOADING STYLE** - 12' Hydraulic Dovetail, Max Ramps, or Straight Deck
- **AXLES** - 2 - 10,000 lb General Duty Electric Brake, Oil Bath
- **CROSS-MEMBERS** - 3" Channel on 16" Centers w/Formed Gussets
- **FRAME** - 16" Engineered Beam (Low Profile)
- **JACK** - 2 - 12,000 lb Drop-Leg Jacks
- **LACE RAIL** - 6" Channel
- **STAKE POCKETS** - 2" x 3/8" Rub Rail w/ Stake Pockets & Pipe Spools
- **STORAGE** - HD V-Tongue Lid w/Gas Shock Assist in Tongue
- **SWAY CONTROL** - Standard on 30' - 40' models
- **TIRES** - ST235/80R16 Radial, Dually
- **TONGUE** - 16" Engineered Tongue w/60K Pintle Eye

Popular Upgrades

- Electric-Over-Hydraulic Drum or Disc Brakes
- 3" Channel Cross-Members on 12" Centers w/Formed Gussets
- 2 - 25,000 lb Two Speed Drop-Leg Jacks



PX212

Tandem Dual Wheel Pintle Hitch

Standard Features

- **AVAILABLE SIZES** - 20' x 102", 22' x 102", 25' x 102", 28' x 102", 30' x 102", 32' x 102", 35' x 102", 38' x 102", 40' x 102"
- **GVWR** - 25,900 lb
- **LOADING STYLE** - 12' Hydraulic Dovetail, Max Ramps, or Straight Deck
- **AXLES** - 2 - 12,000 lb General Duty Electric Brake, Oil Bath
- **CROSS-MEMBERS** - 3" Channel on 16" Centers w/Formed Gussets
- **FRAME** - 16" Engineered Beam (Low Profile)
- **JACK** - 2 - 12,000 lb Drop-Leg Jacks
- **LACE RAIL** - 6" Channel
- **STAKE POCKETS** - 2" x 3/8" Rub Rail w/ Stake Pockets & Pipe Spools
- **STORAGE** - HD V-Tongue Lid w/Gas Shock Assist in Tongue
- **SWAY CONTROL** - Standard on 30' - 40' models
- **TIRES** - ST235/80R16 Radial, Dually
- **TONGUE** - 16" Engineered Tongue w/60K Pintle Eye

Popular Upgrades

- Blackwood Floor
- 14" x 14" x 36" Under-Slung Box
- ST215/75R17.5 Radial Tires



PX310

Triple Dual Wheel Pintle Hitch

Standard Features

- **AVAILABLE SIZES** - 20' x 102", 22' x 102", 25' x 102", 28' x 102", 30' x 102", 32' x 102", 35' x 102", 38' x 102", 40' x 102"
- **GVWR** - 30,000 lb
- **LOADING STYLE** - 12' Hydraulic Dovetail, Max Ramps, or Straight Deck
- **AXLES** - 3 - 10,000 lb General Duty Electric Brake, Oil Bath
- **CROSS-MEMBERS** - 3" Channel on 16" Centers w/Formed Gussets
- **FRAME** - 16" Engineered Beam 20'-32' (Low Profile) 18" Engineered Beam 35' - 40' (Low Profile)
- **JACK** - 2 - 12,000 lb Drop-Leg Jacks
- **LACE RAIL** - 6" Channel
- **STAKE POCKETS** - 2" x 3/8" Rub Rail w/ Stake Pockets & Pipe Spools
- **STORAGE** - HD V-Tongue Lid w/Gas Shock Assist in Tongue
- **SWAY CONTROL** - Standard on 30' - 40' models
- **TIRES** - ST235/80R16 Radial, Dually
- **TONGUE** - 16" Engineered Tongue w/60K Pintle Eye

Popular Upgrades

- 2 - 12,000 lb Hydraulic Jacks
- Air Ride Suspension
- Oak Floor



PX312

Triple Dual Wheel Pintle Hitch

Standard Features

- **AVAILABLE SIZES** - 25' x 102", 28' x 102", 30' x 102", 32' x 102", 35' x 102", 38' x 102", 40' x 102"
- **GVWR** - 30,000 - 40,000 lb
- **LOADING STYLE** - 12' Hydraulic Dovetail, Max Ramps, or Straight Deck
- **AXLES** - 3 - 12,000 lb General Duty Electric Brake, Oil Bath
- **CROSS-MEMBERS** - 3" Channel on 16" Centers w/Formed Gussets
- **FRAME** - 16" Engineered Beam 20'-32' (Low Profile) 18" Engineered Beam 35' - 40' (Low Profile)
- **JACK** - 2 - 12,000 lb Drop-Leg Jacks
- **LACE RAIL** - 6" Channel
- **STAKE POCKETS** - 2" x 3/8" Rub Rail w/ Stake Pockets & Pipe Spools
- **STORAGE** - HD V-Tongue Lid w/Gas Shock Assist in Tongue
- **SWAY CONTROL** - Standard on 30' - 40' models
- **TIRES** - ST235/80R16 Radial, Dually
- **TONGUE** - 16" Engineered Tongue w/60K Pintle Eye

Popular Upgrades

- 40,000 lb GVWR Package
- Electric-Over-Hydraulic Disc Brakes
- HDSS Suspension



PX216

Tandem Dual Wheel Pintle Hitch

Standard Features

- **AVAILABLE SIZES** - 20' x 102", 22' x 102", 25' x 102", 28' x 102", 30' x 102", 32' x 102", 35' x 102", 38' x 102", 40' x 102"
- **GVWR** - 30,000 - 40,000 lb
- **LOADING STYLE** - 12' Hydraulic Dovetail, Max Ramps, or Straight Deck
- **AXLES** - 2 - 16,000 lb General Duty Electric Brake, Oil Bath
- **CROSS-MEMBERS** - 3" Channel on 16" Centers w/Formed Gussets
- **FRAME** - 16" Engineered Beam 20'-32' (Low Profile) 18" Engineered Beam 35' - 40' (Low Profile)
- **JACK** - 2 - 12,000 lb Drop-Leg Jacks
- **LACE RAIL** - 6" Channel
- **STAKE POCKETS** - 2" x 3/8" Rub Rail w/ Stake Pockets & Pipe Spools
- **STORAGE** - HD V-Tongue Lid w/Gas Shock Assist in Tongue
- **SWAY CONTROL** - Standard on 30' - 40' models
- **TIRES** - ST215/75R17.5 16 Ply Radial, Dually
- **TONGUE** - 16" Engineered Tongue w/60K Pintle Eye

Popular Upgrades

- 2 - 25,000 lb Two Speed Drop-Leg Jacks
- 40,000 lb GVWR Package
- 14" x 14" x 36" Under-Slung Box



ASSURANCE

We stand behind our product. Diamond C Trailers come with a 3 year structure warranty.

Tail Options

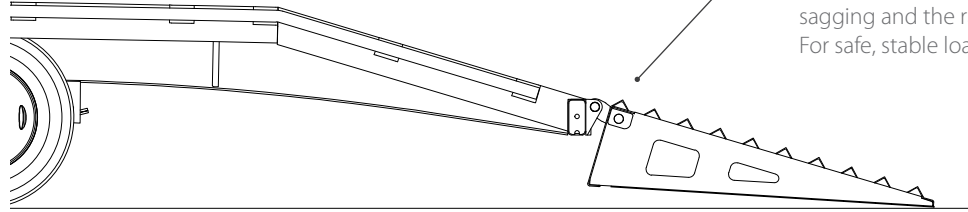

MAX Hinges

The two point ramp hinges are concealed and protected inside of the ramp bodies, not exposed on the bumper like most. Our hinges transfer the force of the load into the knees of the ramps to prevent the back of the trailer from sagging and the ramps from kicking up when loading heavy equipment. For safe, stable loading.

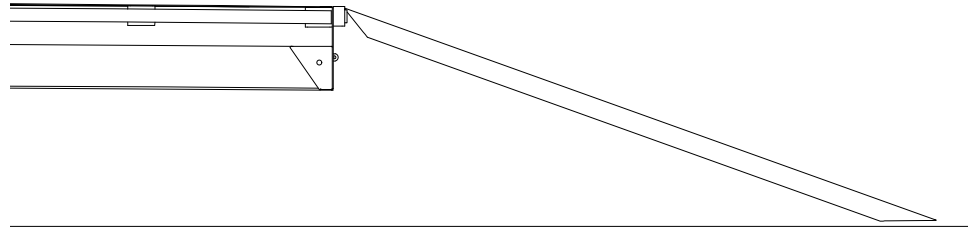

MAX Ramps

44" wide ramps for MAX versatility.
50 ksi steel ramp frames X 4 frames per ramp for MAX strength. HD Spring loaded for easy lifting from deck and from ground.

Straight Deck

With 8' slide-in ramps.
Single piece bumper with light protection.

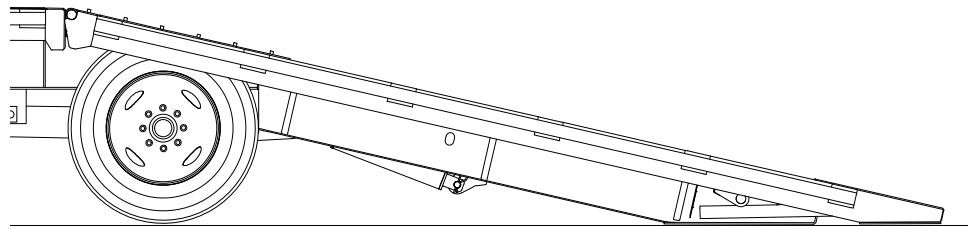

12' Hydraulic Dovetail

12' long with easy to climb, 12.5 degree approach angle. Blackwood rubber-infused runners for traction. Automatic latch for easy operation. Includes wireless remote control.

Powder Coat



Premium Difference Maker Paint Colors

We partnered with Sherwin Williams to develop our own custom designed powder coat finishing system that provides long-lasting, rugged, and beautiful trailer finishes.

STANDARD COLORS

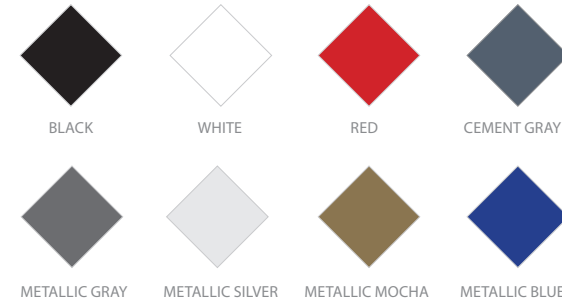

SPECIAL COLORS

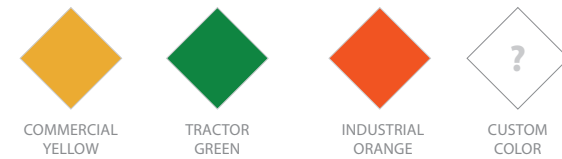

Wheels



SILVER (standard)

BLACK

Genuine Lippert E-Z Lube Axles

For optimal tire wear and longevity, we use only Cambered Axles.



Please contact your authorized Diamond C dealer for questions, additional options, or additional specifications.
OR visit www.diamondc.com to build a trailer to fit your needs.



SEE THE DIFFERENCE

BROFLEET v0719

© Diamond C Trailer Mfg., Road Clipper Enterprises. All illustrations and specifications contained in this brochure are based on the latest product information available at the time of printing. Specifications, standard features, options, components, and colors are subject to change without notice. Some features may be subject to availability, delays, or discontinuance. Trailers shown with optional equipment. Please contact your authorized Diamond C dealer for specifics.

www.diamondc.com

